

## Pressure Gauges - all stainless steel construction HEAVY WORK

MGS18/HW - DS 100-150

MGS20/HW - DS 100-150

01.19

01.21

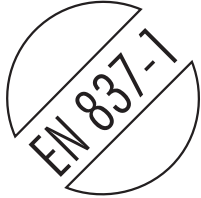

These instruments are designed for use in food, beverage, pharmaceutical, cryogenics, chemical and petrochemical processing industries, and in conventional and nuclear power plants. They are built to resist the most severe operating conditions created by the ambient environment and the process medium. The high strength of the sensing element makes these instrument suitable to withstand high overpressure up to 4 times the full scale value and together with the case filling, they are suitable to high dynamic pulsating pressure. An Argonarc welded case/socket strengthens the whole construction. The **solid-front** version of these instruments is built in accordance with safety specifications of **EN 837-1** and **ANSI B40.1**. The safety construction consists of a **solid separating wall** in stainless steel, placed between the dial and the elastic element and a **blow out back** which is released from the case whenever an internal pressure, due to leaks, is created or the elastic element is broken.

## Functional and constructive characteristics.

### 01.19.1 Standard

#### 01.21.1 Standard, Solid-Front

**Accuracy class:** 1 as per EN 837-1.

**Ambient temperature:** -25...+65 °C.

**Process fluid temperature:** -40...+150 °C.

**Working pressure** (referred to the scale value) : max 90% for pulsating pressure, 100% for static pressure.

**Overpressure:** see table on page 3.

**Protection:** IP 55 as per IEC 529.

**Socket material:** AISI 316L.

**Elastic element:** AISI 316L st.st. seamless tube.

**Welding:** AISI 316 TIG.

**Case:** AISI 304 st.st.

**Ring:** AISI 304 st.st. bayonet lock.

**Blow out disk:** AISI 304 st.st. (solid-front only).

**Window:** safety glass.

**Movement:** stainless steel with internal limit stops for minimum and maximum pressure (reinforced on DS 150) .

**Dial:** aluminium, white with black markings "▼" and symbol at the edges of the full scale value.

**Pointer:** aluminium, micrometric adjustable.

**Window gasket, blow out vent and filling plug:** EPDM.

**Blow out disk gasket:** EPDM (solid-front only).

### 01.19.2 Fillable

#### 01.21.2 Fillable, Solid-Front (Vertical type only)

**Protection:** IP 67 as per IEC 529.

**Window:** safety glass.

**Note:** suitable for glycerine filling; other filling fluids available on request (see OPTIONS table on pag. 4) .

**Other features:** as standard types.

### 01.19.3 Liquid filled

#### 01.21.3 Liquid filled, Solid-Front (Vertical type only)

**Accuracy class:** 1,6 as per EN 837-1.

**Ambient temperature:** max +65 °C, (see DAMPING LIQUIDS table on page 4 for further information).

**Process fluid temperature:** +65 °C.

**Protection:** IP 67 as per IEC 529.

**Window:** safety glass.

**Damping liquids:** glycerine 98%, (see DAMPING LIQUIDS table on page 4 for others filling fluids).

**Other features:** as standard types.

## 01.19: TYPE, DIMENSION AND WEIGHTS

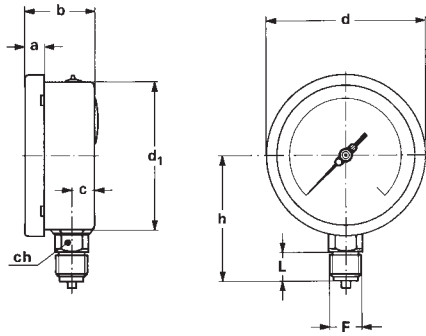
**TYPE A**

stem mounting;  
lower connection.

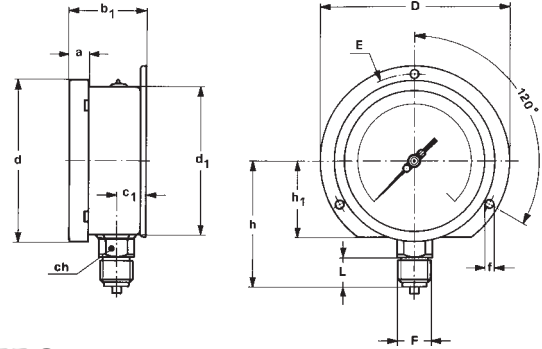
**TYPE C**

surface mounting, back flange,  
lower connection.

DS	Type	a	b	b <sub>1</sub>	c	c <sub>1</sub>	d	d <sub>1</sub>	f	h <sub>1</sub>	D	E	ch	Weight 19.1-2	Weight 19.3
100	A-C	13	48,5	52,5	15	19	110,5	101	6	52	130	118	22	0,53 Kg.	0,86 Kg.
150	A-C	15	50,5	54	15,5	19	161	149,5	6	85	190	175	22	1,02 Kg.	1,72 Kg.

(dimensions : mm.)

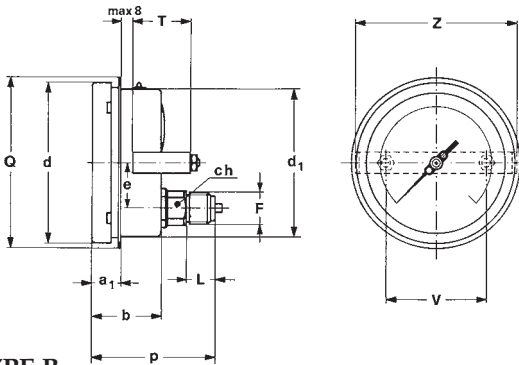
**TYPE B**

flush mounting, "U"-Clamp;  
back connection.

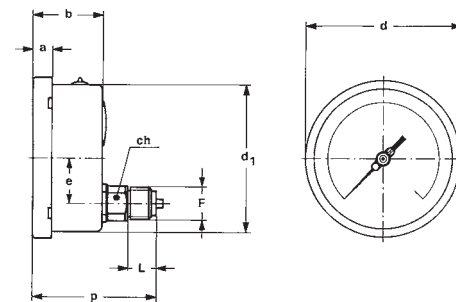
**TYPE D**

stem mounting;  
back connection.

DS	Type	a	a <sub>1</sub>	a <sub>2</sub>	b	d	d <sub>1</sub>	e	f	h <sub>1</sub>	D	E	Q	T	V	Z	ch	Weight 19.1-2	Weight 19.3
100	B-D-E	13	20	20	48,5	110,5	101	31	6	/	132	118	112	41,5	70	112	22	0,52 Kg.	0,85 Kg.
150	B-D-E	15	20,5	25,5	50,5	161	149,5	48	6	85	190	175	164	41,5	106	155	22	0,95 Kg.	1,65 Kg.

(dimensions : mm.)

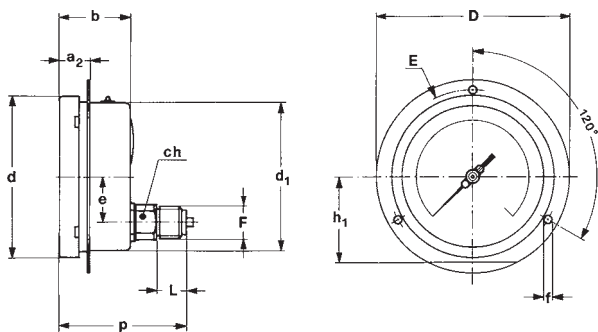
**TYPE E**

flush mounting, front flange;  
back connection.

**PROCESS CONNECTIONS**

F	CODE	DS 100			DS 150		
		L	h	p	L	h	p
1/4" BSP M	21M	13	79	85 (93,5)	13	110	83,5 (94)
1/4" NPT M	23M	15	81	87 (95,5)	15	112	85,5 (96)
3/8" BSP M	31M	16	86	87 (95,5)	16	117	85,5 (96)
3/8" NPT M	33M	16	86	87 (95,5)	16	117	85,5 (96)
1/2" BSP M	41M	20	86	87 (95,5)	20	117	85,5 (96)
1/2" BSP M tapered	42M	20	86	87 (95,5)	20	117	85,5 (96)
1/2" NPT M	43M	20	86	87 (95,5)	20	117	85,5 (96)
M20 x 1,5 M	97M	20	86	87 (95,5)	20	117	85,5 (96)

(the dimentions between brackets are referring to type 01.21)

## 01.21: TYPE, DIMENSIONS AND WEIGHTS

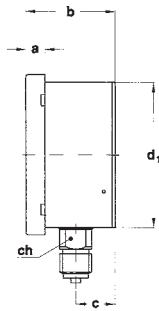
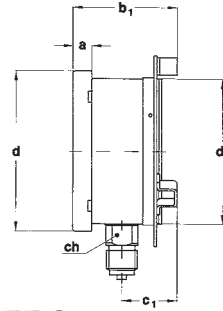
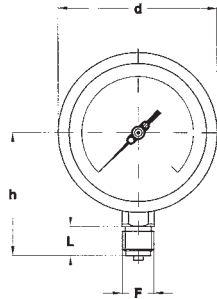
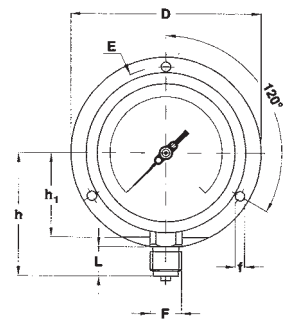
**TYPE A**stem mounting;  
lower connection.**TYPE C**surface mounting, back flange;  
lower connection.

DS	TYPE	a	b	b <sub>1</sub>	c	c <sub>1</sub>	d	d <sub>1</sub>	h <sub>1</sub>	f	D	E	ch	Weight 21.1-2	Weight 21.3
100	A-C	13	62,5	74	29,5	41	110,6	101	-	6	132	118	22	0,65 Kg.	0,98 Kg.
150	A-C	15	64	75,5	30	41,5	161	149,6	85	6	190	175	22	1,2 Kg.	2 Kg.

(dimensions : mm.)

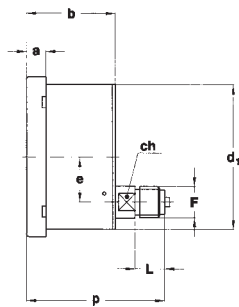
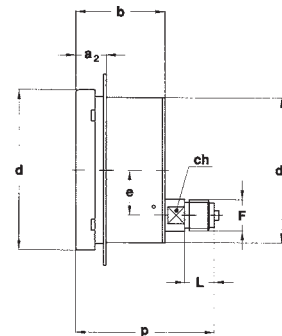
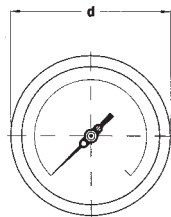
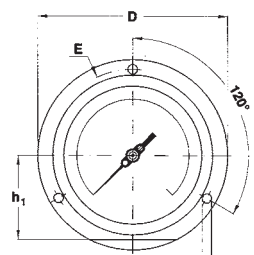
**TYPE D**stem mounting;  
back connection.**TYPE E**flush mounting, front flange;  
back connection.

DS	TYPE	a	a <sub>2</sub>	b	d	d <sub>1</sub>	e	f	h <sub>1</sub>	D	E	ch	Weight 21.1
100	D-E	13	20	61	110,6	101	31	6	-	132	118	17	0,7 Kg.
150	D-E	15	25,5	64	161	149,6	47,8	6	85	190	175	17	1,15 Kg.

(dimensions : mm.)

## RANGES

## PRESSURE

Ranges (bar)	0...1	0...1,6	0...2,5	0...4	0...6	0...10	0...16	0...25	0...40	0...60	0...100	0...160	0...250	0...400	0...600	0...1000
Overpressure (bar)	4	6	10	16	25	40	48	75	80	120	200	320	500	800	1200	1600

M.U. available: bar; kPa; MPa; bar/psi; bar/Kpa; bar/Mpa

Ranges (psi)	0...15	0...30	0...60	0...100	0...160	0...200	0...300	0...400	0...600	0...1000	0...1500	0...2000	0...3000	0...4000	0...6000	0...10000	0...15000
Overpressure (psi)	60	120	240	400	480	600	900	1000	1200	2000	3000	4000	6000	8000	10000	15000	20000

M.U. available: psi; psi/Kpa; psi/bar; psi/Kg/cm<sup>2</sup>

## VACUUM &amp; COMPOUND

Ranges (bar)	-1...0	-1...0,6	-1...1,5	-1...3	-1...5	-1...9	-1...15	-1...24
Overpressure (bar)	3	5	9	15	23	39	47	75

M.U. available: bar; kPa; MPa; bar/psi; bar/Kpa; bar/Mpa

Ranges (psi) (1)	-30...0	-30...15	-30...30	-30...150
Overpressure (psi)	45	100	125	450

M.U. available: psi; psi/Kpa; psi/bar; psi/Kg/cm<sup>2</sup>  
(1) vacuum M.U.: InHg

all stainless steel construction HEAVY DUTY  
MGS18/HW - MGS20/HW - DS 100-150

01.19/01.21

**01.19 : OPTIONS** - "E" = DS100; "G" = DS150.

DESCRIPTION	CODE	01.19.1 (standard)	01.19.2 (fillable)	01.19.3 (filled)
AISI 316 st.st. case and ring	C40	E G	E G	E G
Non adjustable pointer	L01	E G	E G	E G
Suitable for silicone oil filling (4)	P01		E G	
Silicone oil filling (4)	S10			E G
Tropicalization	T01	E G	E G	E G
AISI 316 st.st. label	T25	E G	E G	E G
Rescritor screw 0,7 mm.	V11	E G (3)	STD	STD

**01.21 : OPTIONS** - "E" = DS100; "G" = DS150 (differences to 01.19 options).

DESCRIPTION	CODE	01.21.1 (standard)	01.21.2 (fillable)	01.21.3 (filled)
AISI 316 st.st. case and ring	C40	E	E	E
"Fluorolube" filling (4)	F30			E G
Oxygen service MO49	P02	E G	E G (2)	E G (1)

- (1) to be ordered only with "Fluorolube" (option F30).  
 (2) to be ordered with option "P01".  
 (3) std for pressure ranges <sup>3</sup> 60 bar.  
 (4) window gasket: silicone rubber; blow out vent & filling plug: VITON.

**HOW TO ORDER**

<b>01</b>	01- bourdon tube pressure gauges
<b>19</b>	19 - MGS18/HW 21 - MGS20/HW
<b>2</b>	1 - standard 2 - fillable version 3 - filled version
<b>C</b>	A - lower connection - stem mounting B - back connection - flush mounting, "U" -clamp C - lower connection - surface mounting, back flange D - back connection - stem mounting E - back connection - flush mounting, front flange
<b>E</b>	E - DS100 G - DS150
<b>2</b>	1 - up to 2,5 bar 2 - from 4 to 40 bar 3 - over 40 bar
<b>0/10 bar</b>	see ranges table
<b>41M</b>	21M - 1/4" BSP M 23M - 1/4" NPT M 31M - 3/8" BSP M 33M - 3/8" NPT M 41M - 1/2" BSP M 42M - 1/2" BSP M TAPERED 43M - 1/2" NPT M 97M - M20 x 1,5
<b>L01</b>	see options table

**INSTRUMENTS FOR OXYGEN SERVICE**

To suit safety criteria of standard EN837-1/2, the pressure gauges for oxygen service must be solid-front type (with baffle wall and safety bursting back).

Pressure gauges suitable for this service are 01.21 DS 100-150, detailed on page 3.

**DAMPING LIQUIDS**

Damping liquids	Ambient temperature
Glycerine 98%	+15...+65 °C (+60...+150 °F)
Silicon oil	-45...+65 °C (-50...+150 °F)
"Fluorolube"	-60...+65 °C (-76...+150 °F)

Glycerine or silicone should not be used with highly oxidizing agents such as oxygen, chlorine, nitric acid or hydrogen peroxide, because of danger of spontaneous chemical reaction, inflammability or exposition. The use of fluorinated fluid and solid-front instruments type 01.21 are recommended in these cases.

**ACCESSORIES**

**Diaphragm seals:** a complete range of diaphragm seals are available with a choice of materials of construction. Specifically for corrosive and difficult process fluids plus hygienic applications. For further details refer to the relative data-sheet "04".

**Valves:** for construction details and for use limits refer to our data-sheet 05.

**Pigtail and siphons:** recommended with temperatures of 65°C (150°F) or over. For further details refer to our data-sheet 05.5xx.

**Pressure snubbers:** for further details refer to our data-sheet 05.450-470.



**DRUCK & TEMPERATUR Leitenberger GmbH**  
 Postfach 64 • D-72136 Kirchentellinsfurt • Germany  
 Tel.: 0 71 21 - 9 09 20 - 0 • Fax: 0 71 21 - 9 09 20 - 99  
 E-Mail: dt-info@leitenberger.de  
 INTERNET-Site: http://www.leitenberger.de